

Appendix A: Fixture Specifications

- High output xenon lamp source
- 11 dichroic colors plus white
- Variable speed strobe
- High resolution stepper motors
- Precision galvanometers
- Self diagnostics
- Lightweight aluminum construction
- Anti-reflective emission window
- Auto remote cooling system shutdown
- Variable speed color rotation
- Balanced RS-422 serial data link
- 650 hours average lamp life
- X & Y scan angles: 60° x 60°
- Voltage selectable:
 - 100 Volts @ 50/60Hz
 - 120 Volts @ 50/60Hz
 - 240 Volts @ 50/60 Hz
- Power consumption:
 - (Normal mode)
 - 7 amps @ 100 V/50Hz
 - 6 amps @ 120V/60 Hz
 - 3 amps @ 230 V/50 Hz
- Dimensions:
 - 610 mm L x 330 mm W x 200 mm H
 - 24 in L x 13 in W x 8 in H
- Weight:
 - 23 kg (50 lbs)

specifications subject to change without prior notice

Appendix B: Fixture Illustrations

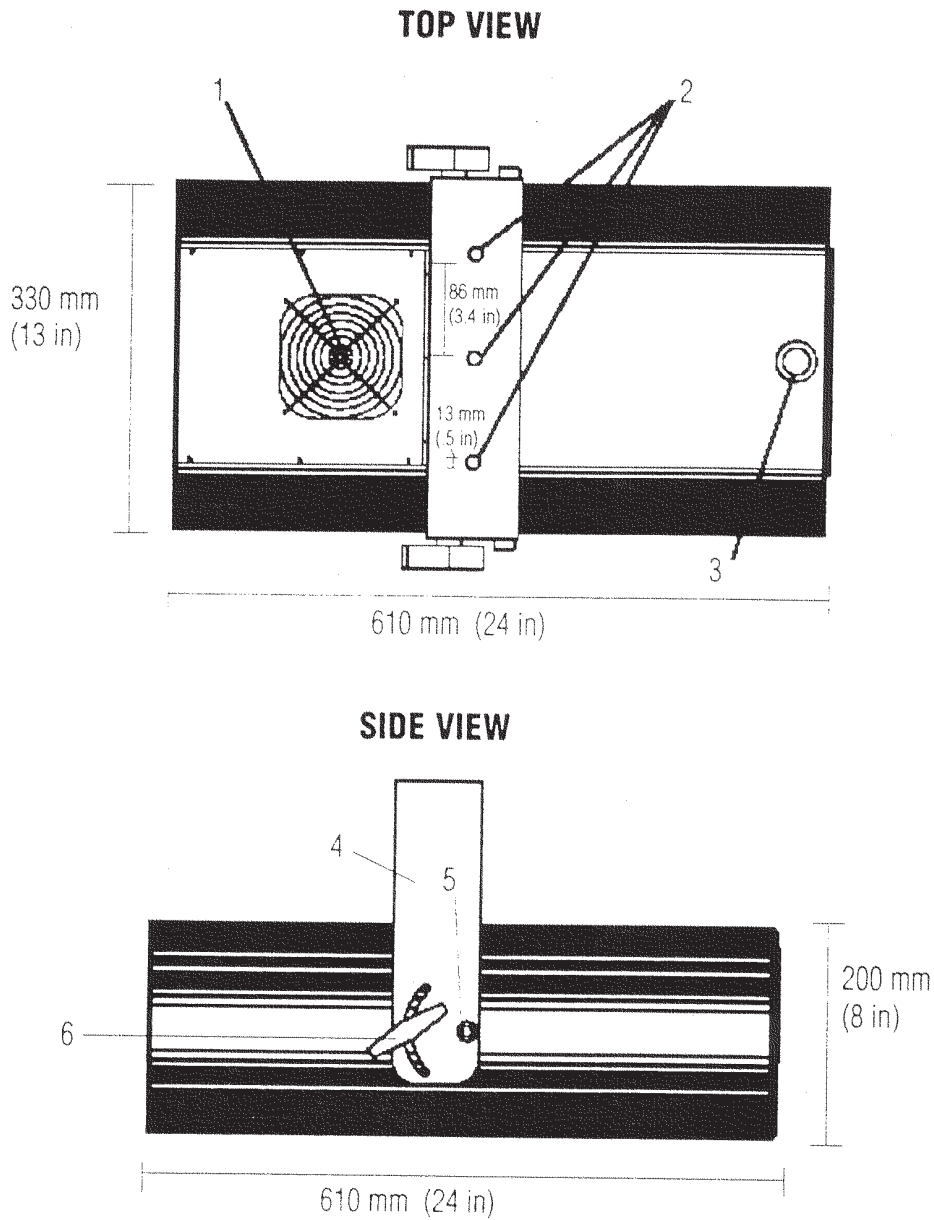

Emulator Fixture Illustration: Top View & Side View
(See Appendix A for fixture specifications.)

1. COOLING FAN
2. YOKE MOUNTING HOLES
3. TOP DOOR THUMBSCREW
4. YOKE
5. ALLEN CAP SCREW BOLT
6. CLAMPING T-HANDLE

Appendix B: Fixture Illustrations

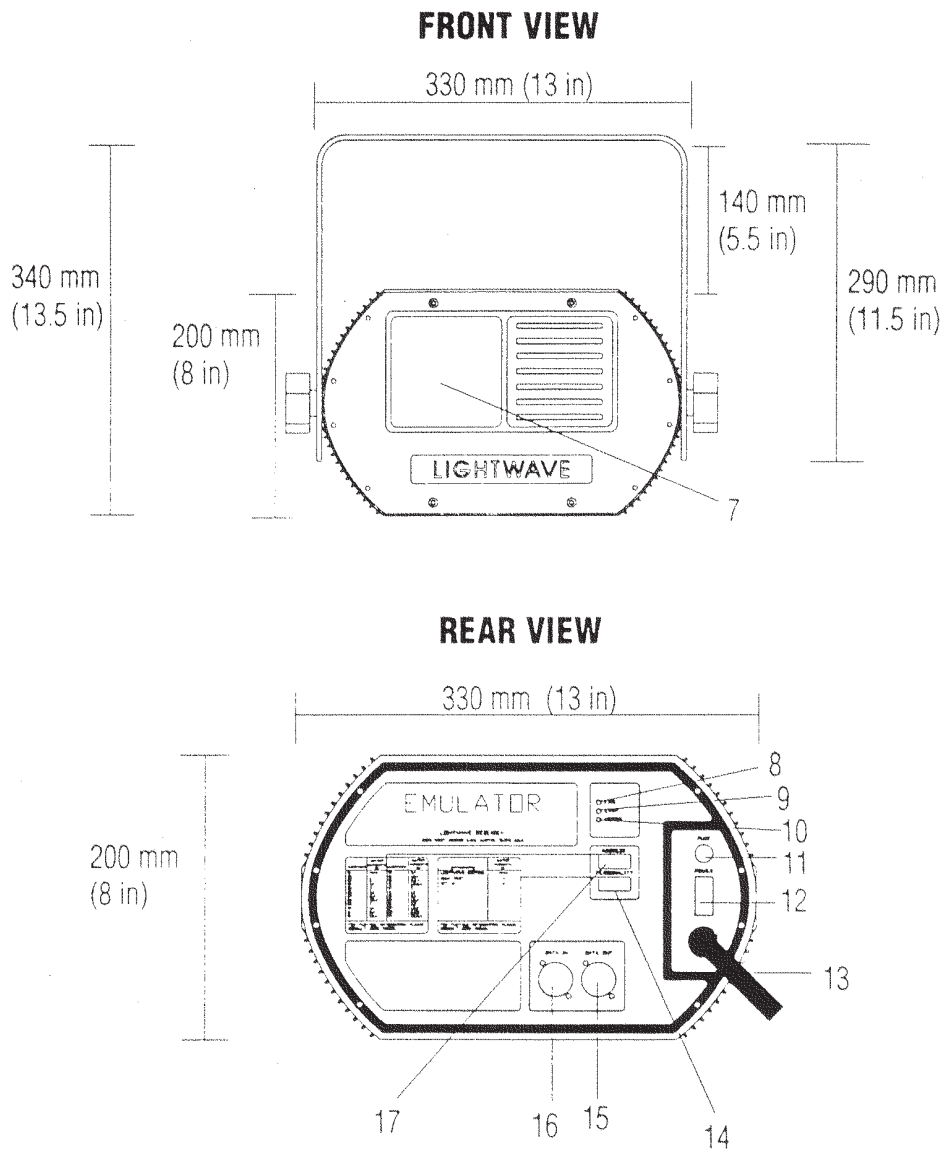

Emulator Fixture Illustration: Front View & Rear View
(See Appendix A for fixture specifications.)

- 7. ANTI-REFLECTIVE EMISSION WINDOW
- 8. FAN INDICATOR LED
- 9. LAMP INDICATOR LED
- 10. MOTOR INDICATOR LED
- 11. FUSE
- 12. POWER SWITCH
- 13. AC LINE CORD
- 14. PERSONALITY DIP SWITCH
- 15. DATA OUT CONNECTION
- 16. DATA IN CONNECTION
- 17. ADDRESS DIP SWITCH

Appendix C: Controller Specifications

- 99 infinitely variable patterns
- 891 programmable scenes
- 1023 programmable presets
- 24 individual addresses
- Scrolling and alphanumeric graphic capability
- Application-specific editing functions
- Inductive joystick
- Remote operation capability
- Stereo audio inputs
- Self diagnostics
- Rack mountable - 4 units high
- Fixture exclusion
- Master/slave capability
- Positive feel switches
- Locking key switch
- Voltage selectable:
 - 100 Volts @ 50/60Hz
 - 120 Volts @ 50/60Hz
 - 240 Volts @ 50/60 Hz
- Frequency selectable:
 - 50 Hz
 - 60Hz
- Dimensions:
 - 180 mm H x 480 mm W x 280 mm D
 - 7 in H x 19 in W x 11 in D
- Weight:
 - 8.1 kg (18 lbs)

specifications subject to change without prior notice